



6 VOLT / P-16

- CAPACITY** 370 Ah
- MATERIAL** Polypropylene
- BATTERY** Deep-Cycle Flooded/Wet Lead-Acid Battery
- COLOR** Black
- WATERING** Required

ELECTRICAL SPECIFICATIONS

VOLTAGE	6			
CELL(s)	3			
CAPACITY^A MINUTES	185 @ 75 AMPS			
CAPACITY^B AMP-HOURS (Ah)	5	10	20	100
	303	340	370	411
ENERGY (kWh)	2.47 @ 100 Hr			

CHARGING INSTRUCTIONS

CHARGER VOLTAGE SETTINGS (AT 77°F/25°C)					
SYSTEM VOLTAGE	6V	12V	24V	36V	48V
Bulk Charge	7.41	14.82	29.64	44.46	59.28
Float Charge	6.75	13.50	27.00	40.50	54.00
Equalize Charge	8.10	16.20	32.40	48.60	64.80

Do not install or charge batteries in a sealed or non-ventilated compartment. Constant under or overcharging will damage the battery and shorten its life as with any battery.

PHYSICAL SPECIFICATIONS

BCI	903		
MODEL	P-16		
TERMINAL TYPE^C	EMBEDDED UNIVERSAL TERMINAL REVERSE		
DIMENSIONS^D INCHES (mm)	LENGTH	WIDTH	HEIGHT ^E
	12.31 [313]	6.85 [174]	16.41 [417]
WEIGHT^F LBS. (kg)	98 [44.5]		
HANDLE	ROPE HANDLE		
INSTALLATION ORIENTATION	VERTICAL/UPRIGHT		

CHARGING TEMPERATURE COMPENSATION

ADD	SUBTRACT
0.005 volt per cell for every 1°C below 25°C 0.0028 volt per cell for every 1°F below 77°F	0.005 volt per cell for every 1°C above 25°C 0.0028 volt per cell for every 1°F above 77°F

OPERATIONAL DATA

OPERATING TEMPERATURE	SELF DISCHARGE
-4°F to 113°F [-20°C to +45°C]. At temperatures below 32°F [0°C] maintain a state of charge greater than 60%.	5 - 15% per month depending on storage temperature conditions.

STATE OF CHARGE MEASURE OF OPEN-CIRCUIT VOLTAGE

PERCENTAGE CHARGE	SPECIFIC GRAVITY	CELL	6 VOLT
100	1.277	2.122	6.37
90	1.258	2.103	6.31
80	1.238	2.083	6.25
70	1.217	2.062	6.19
60	1.195	2.040	6.12
50	1.172	2.017	6.05
40	1.148	1.993	5.98
30	1.124	1.969	5.91
20	1.098	1.943	5.83
10	1.073	1.918	5.75



BATTERY DIMENSIONS

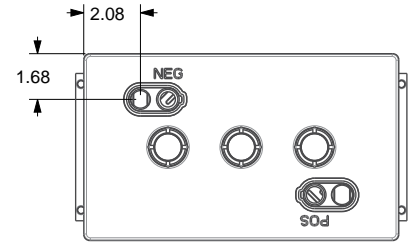
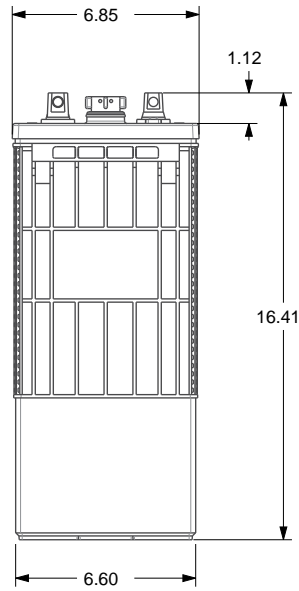
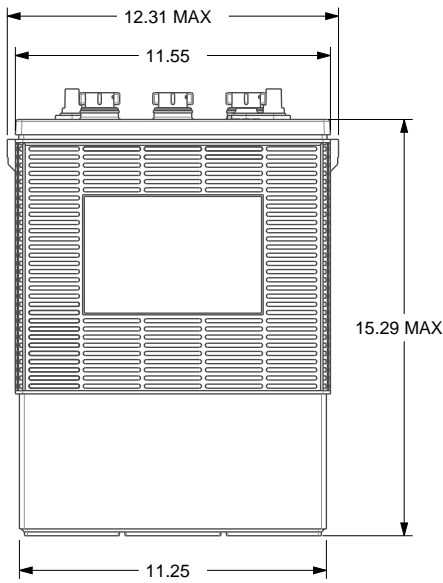

TERMINAL SPECIFICATIONS^C

TYPE	EUTR
DESCRIPTION	EMBEDDED UNIVERSAL TERMINAL REVERSE
HEIGHT INCHES [mm]	1.10 [28]
TORQUE POUNDS [Nm]	95-105 [11-12]
BOLT	HOLE SIZED FOR 5/16" -18 BOLT

PERFORMANCE

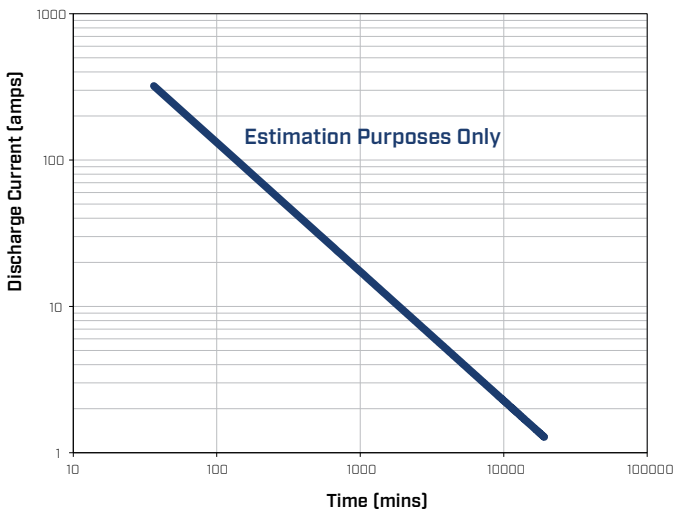

PERCENT CAPACITY VS. TEMPERATURE

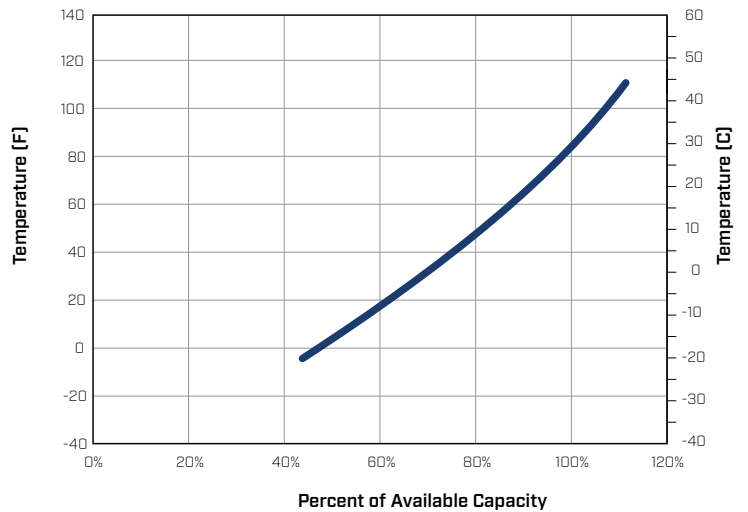

PACER BATTERY COMPANY
WITH QUALITY SYSTEM
CERTIFIED BY DNV
ISO 9001:2015

Designed in compliance with applicable BCI standards.
Tested in compliance to BCI standards.



- A. The number of minutes a battery can deliver when discharged at a constant rate at 80°F (27°C) and maintain a voltage above 1.75 V/cell. Capacities are based on peak performance.
- B. The amount of amp-hours (Ah) a battery can deliver when discharged at a constant rate at 80°F (27°C) and maintain a voltage above 1.75 V/cell. Capacities are based on peak performance.
- C. Terminal images are representative only.

- D. Dimensions may vary depending on type of handle or terminal. Batteries should be mounted with 0.5 inches (12.7 mm) spacing minimum.
- E. Height taken from bottom of the battery to the highest point on the battery. Heights may vary depending on type of terminal.
- F. Weight may vary.

P2025005-P-16-Pacer-Datasheet

