

Skylla-TG 24/30 and 24/50 GMDSS

with battery time to go prediction

www.victronenergy.com



**Skylla
TG 24 30 GMDSS**

GMDSS

The Global Maritime Distress & Safety System (GMDSS) was developed by the International Maritime Organisation (IMO) to improve maritime distress and safety communications.

Power supply

The Skylla TG has proven itself to be an excellent battery charger and power supply for GMDSS applications. However, when using a standard Skylla Charger, additional equipment is needed to perform the monitoring and alarm functions required for GMDSS.

Installation made easy: the Skylla GMDSS

The Victron Skylla GMDSS Charger has been designed to provide all required monitoring and alarm data. Both the battery and the GMDSS system are connected directly to the charger. Data and alarms are displayed on a digital panel (VE.Net GMDSS panel, to be ordered separately). A standard eight wire UTP-cable connects the charger to the panel.

No adjustments needed

The whole system is 'click and go': the panels are pre-programmed for GMDSS functionality. A simple, intuitive menu allows changing of settings if required.

Battery time to go

The Skylla GMDSS charger has a built-in battery controller. The capacity of the battery is fully monitored so the panel can even indicate the 'time to go' in case of a power supply black out.

Perfect charger for any type of battery

Charge voltage can be precisely adjusted to suit any VRLA or flooded battery system.

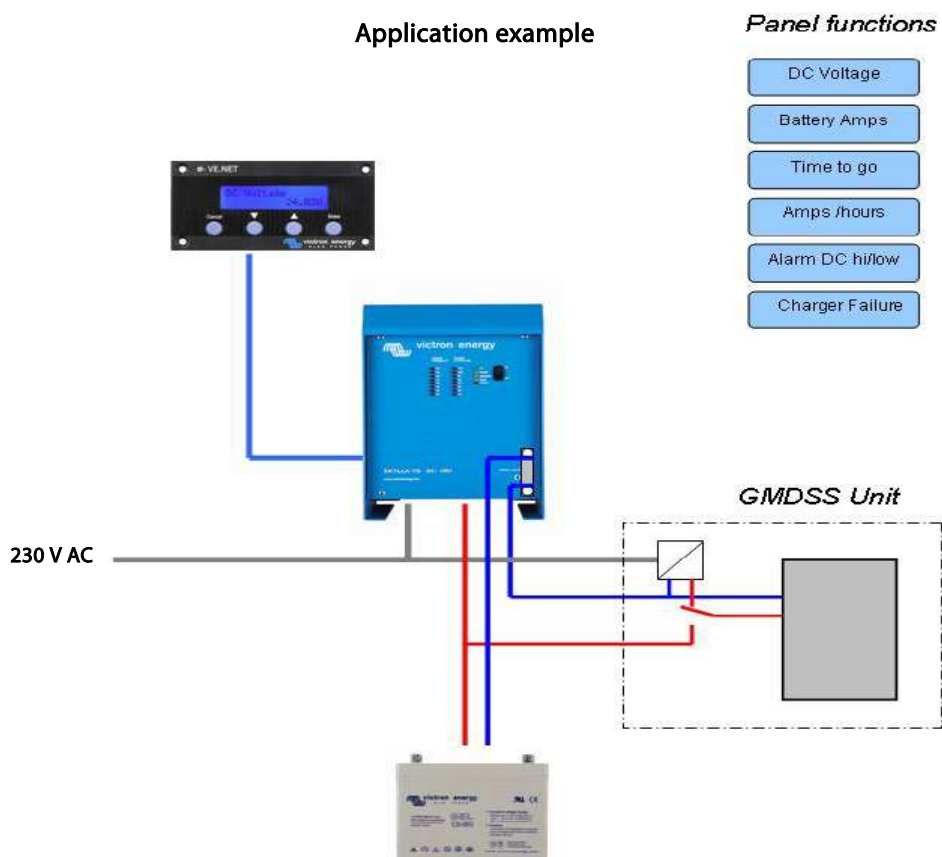

Skylla-TG	24/30 GMDSS	24/50 GMDSS
Input voltage (V AC)	120 / 230	
Input voltage range (V AC)	90 - 265	
Frequency (Hz)	45-65	
Power factor	1	
Charge voltage 'absorption' (V DC)	28,5	
Charge voltage 'float' (V DC)	26,5	
Charge current (A)	30 (limited to 22 A at 110 V AC)	50
Charge characteristic	IUoUo (three step)	
Temperature sensor	√	
Can be used as power supply	√	
Forced cooling	√	
Protection (1)	a, b, c, d	
Operating temp. range	-40 to +50°C (-40 - 122°F)	
Humidity (non-condensing)	max 95%	
ENCLOSURE		
Material & Colour	aluminium (blue RAL 5012)	
Battery-connection	Two 1,5 m cables	
GMDSS connection	One 1,5 m cable (+ to be taken directly from the battery)	
230 V AC-connection	Three wire 2,5 mm ² (AWG 6) cable Length: 2 m	
Protection category	IP 21	
Weight kg (lbs)	6 (13)	
Dimensions hxxwx d in mm (hxxwx d in inches)	485x250x147 (19.1x9.9x5.8)	
ACCESORIES		
VE.Net GMDSS panel	To be ordered separately	
UTP-cable	To be ordered separately	
STANDARDS		
Safety	EN 60335-1, EN 60335-2-29	
Emission Immunity	EN 55014-1, EN 61000-3-2	
Immunity	EN 55014-2, EN 61000-3-3	
Maritime Nav. & Radiocomm.	IEC 60945	
1) Protection key: a) Output short circuit b) Battery reverse polarity detection	c) Battery voltage too high d) Temperature too high	2) Up to 40°C (100°F) ambient

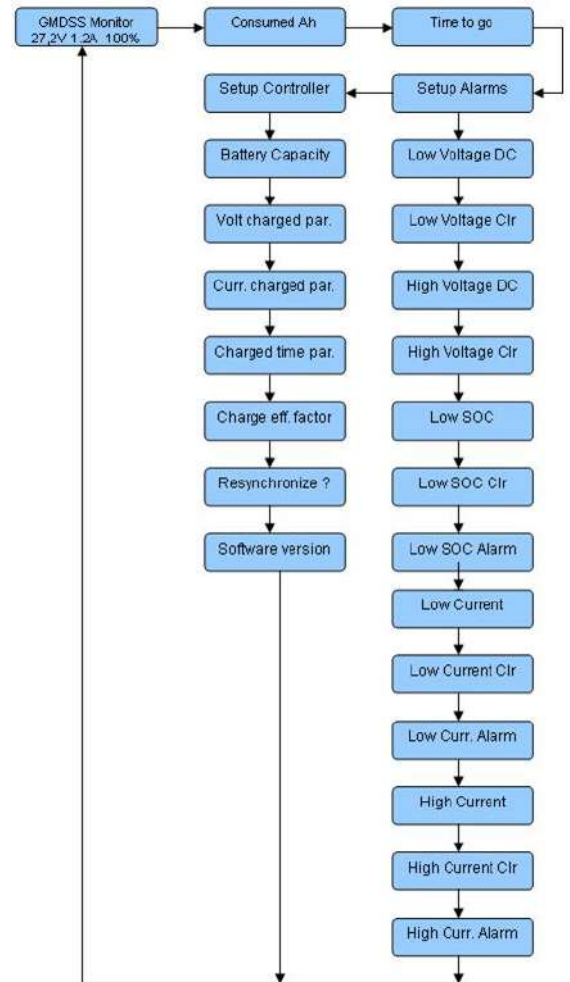

Remote panel GMDSS

The remote panel allows easy access to all important data. Alarm settings are pre-set but can also be reprogrammed.